



**Los L.,
Kukharets S.,
Tsyvenkova N.,
Golubenko A.,
Tereshchuk M.**

SUBSTANTIATION OF THE STRUCTURE THEORY OF DESIGN OF TECHNOLOGICAL MACHINES AND DEVICES

Розглядається теорія структури конструкцій технологічних машин та приладів з отриманням кількісних критеріїв на її основі та приклади застосування представленої теорії. Обґрунтовуються критерії складання, ремонтпридатності, уніфікації та функціональної насиченості, які дозволяють давати кількісну оцінку конструкціям на стадії їх розробки. Доведено, що вони об'єктивно відображають технічну досконалість конструкцій, оскільки не залежать від факторів, що змінюються з часом, наприклад, таких як собівартість.

Ключові слова: теорія структури конструкцій, критерії складання та ремонтпридатності, теорема існування конструкцій.

1. Introduction

Insufficient level of manufacturability, maintainability and unification of the design of machines and devices is largely due to the lag in studies on the formalization of the basics of design. The creation of automated design systems, which are mainly implemented routine processes of design and construction, does not reduce the relevance of research on the formalization of structures, by determining the objective criteria for evaluating products. Since much of the work related to engineering creativity, in our time can't be passed to machine design.

2. The object of research and its technological audit

The object of research is the structure theory of design of technological machines and devices. Any scientific theory should have a basis. Such basis is a general principle that links all the elements of the theory. Let's accept a general principle, which can be called the principle of unrestricted separation of structures and any combination of its elements. Briefly call it the principle of separation-connection.

The essence is this: each design of the machine or device can be divided into an arbitrary number of elements of different shapes and combine them in any real version. It is clear that the above partitioning and conjunction of construction are carried out first on its display (drawing, sketch), and in real design the result of various partitions, combinations and connections is embodied. It should be noted that in theory, along with a general principle, there may be principles of a lesser degree of generality. They specify the basic principle.

For the structure theory of design, the idea is expressed by the following definition: it is possible to a priori quantitative evaluation of the structure of machine and instrument designs for manufacturability, unification and other indicators on the basis of identifying structural design features and creating quantitative criteria.

Existing methods for evaluating designs do not give satisfactory results when using them at the development stage. For example, in [1] 13 basic and additional indicators of manufacturability are established. And all of them should be defined relative to the basic product or basic indicators [2]. This approach reduces the reliability of the assessment, since the choice of the base product is carried out at the reached level and therefore the design can't be objectively assessed at the design stage due to the use of information on labor intensity and cost in the indicators. That is, a posteriori values that can be obtained after the completion of design, development in production, determination of batch volumes and development of technology.

To improve the quality of design and reduce the time required to create new designs, objective quantitative criteria for evaluating products at the development stage are required. Such criteria can be obtained by formalization, which is based on the internal properties of the product. Exceptional use in terms of labor intensity and cost values reduces the reliability of the assessment for their dependence on the type of production and the level of technology of a particular manufacturing enterprise.

3. The aim and objectives of research

The aim of research is determination of the quantitative criteria that will allow a priori evaluation of the corresponding structures of designs to the specified levels of manufacturability, maintainability, unification, automation, etc. This will allow to identify patterns and determine the ways of optimizing the design structure at the design stage, coordinating them with technological equipment, and introducing verified concepts of evaluation of designs with quantitative criteria in standards.

To achieve this aim, it is necessary to solve the following tasks:

1. To prove the theory of the existence of an infinite set of designs taking place with a certain underlying constructive series.

2. To create a technique for obtaining such plurality of designs by adding separate constructive elements or features corresponding to certain properties.

3. To identify the patterns and determine ways to optimize the structure of designs, by coding them and the chain of successive transformations.

4. To show the feasibility of introducing the presented theory.

4. Research of existing solutions of the problem

The search for regularities in the structure of designs of machines and devices can be rationally carried out using set theory, the calculation of predicates of the first order, the theory of groups [3–6]. This makes it possible to create objective quantitative criteria for an a priori assessment of the manufacturability of assembly, maintainability, unification, functional saturation of designs, contributing to their improvement.

Formalization of designs is also required to intensify the design process and improve the quality of documentation, developed by expanding the range of design tasks that are solved by CAD. It is also advisable the suitability of this formalization for intellectual (manual) design.

The general principle is laid in the foundation of the theory as a basis for deduction, as a synthesizing principle. From the general principle all concepts, laws and other elements of the theory develop. For example, the basis of the theory of dialectics is the principle of development. After the completion of the theory, the principles develop and improve [7].

According to [8–13], in theory the necessary condition is the existence of an idea, from which follows the goal (goals), the perspective in the direction from the study to the practical application of the results. In the opinion of the authors [3, 4, 7, 14–17] the whole theory potentially consists in concepts (terms), treating the concept as an abstraction [18, 19], a mental reflection of the general essential features of the object, the phenomenon, the scientific fact. When formulating concepts, they strive to make the object defined, not used in its definition.

When constructing a theory, it is necessary to minimize its initial assumptions, that is, to strive for a smaller number of axioms and basic concepts [5]. All parts of the theory must satisfy the requirements below.

According to the analysis of literary sources [7, 14, 15, 20, 21], the formal expression of the logical conclusion of the scientific theory is formalization, which links the structure of the theory: principles, judgments, concepts, axioms, theorems, consequences, laws and other elements of the theory. The main purpose of formalization is supplement and refining the knowledge. However, excessive formalization impoverishes the theory.

The construction of a theory on the basis of the axiomatic method ensures the rigidity of construction, limits the excess in determining the truth of scientific statements [9, 22]. The axiomatic method assumes the existence of such axiom system, in which significant positions in the theory are derived logically from the axioms. The adopted system of axioms must satisfy the requirements of consistency, completeness and independence [4, 15].

In addition to the axioms, the content theory itself must satisfy the requirements of consistency and completeness,

and a distinction is made between formal and semantic consistency, which are equally related. Formally consistent is the theory, if there is no such formula that is its theorem, that the negation of the given formula is also a theorem of the given theory [19]. Semantically consistent is the theory, if it is a model. The completeness of the theory should be affirmed if it contains a definite sequence, or a definite set of formulas, and the indicated procedure by which all the above formulas can be proved [21]. For a meaningful theory, this approach does not contradict K. Gödel's incompleteness theorems, since the results of his scientific work do not imply the impossibility of proving consistency by finite means [19].

The analysis of the above allows, with the aim of matching the system of axioms and the content theory to the above requirements, in the further scientific investigation, use the predicate calculus of the first order for their formalization. This choice is advisable for the following reasons. The axioms of the predicate calculus of the first order satisfy the requirements of consistency, completeness and independence. Applying these axioms (their models) in the theory of content let's pass these properties to the applied theory, that is, let's obtain a consistent, complete and independent system of axioms. Substantial theories are characterized by the fact that the axioms add their own axioms, which take into account the specificity of a particular theory. To our own axioms, the requirements of general significance do not apply.

Thus, using the formalization of the classical predicate calculus to describe the applied theory, while preserving the mapping of all axioms and theorems of the calculus to the content theory, it can be considered consistent and complete, reinforcing this assertion by referring to the fulfillment of this derivation for algebraic systems [18].

For this reason, for further research in the direction of creating a theory of design structures, one should use the features of constructing algebraic systems [10, 11]. Using these mathematical tools it will be possible:

- to solve problems of obtaining quantitative criteria for a priori evaluation of machine and instrument designs;
- to derive the design rules;
- to formalize the unification of designs and combine it with the unification of technological equipment;
- to formulate the parts formulas with the optimization of products based on them, etc.

5. Methods of research

The axiom formulation completes the construction of the foundation of the axiomatic theory. The next step is the proof of the theorems. Although the content of the considered theory is not mathematical, but technical objects, approach to statements about the construction, as to theorems, creates conditions for the correctness of the presentation, since the theorem, being a link in the apparatus of deduction, must be proved in the framework of certain rules.

The proofs of existence theorems are present in many theories. It may seem that in substantive theories their evidence is the fulfillment of formal requirements for constructing a theory. However, in mathematics the proofs of existence theorems (for example, the initial, integrals, etc.) are an effective way of its development [21]. This

remark applies to other sciences. «In the problems of mechanics and physics, the existence theorems are of great interest, since with their help it is possible to obtain a rational way of testing the adequacy of the theory (which constructs facts and phenomena of the physical world in some mathematical scheme) that does not depend on the consideration of physical plausibility and is not connected with experiments. Unfortunately, existence theorems are the most difficult part of the theory» [7, 20].

For construction, the existence theorem for designs is useful for several reasons. First, it, in spite of the inertia of thinking, can eliminate discussions among constructors (and thus save time) about the possibility or impossibility of any concrete constructions, since the fact of the existence of all constructions with real parameters will be brought up by this theorem. In addition, the existence theorem for designs implies useful consequences.

If to draw parallels with mathematics, the proof of the existence theorem for design, even if the theorem seems obvious, is necessary from the standpoint of respecting the internal logic of constructing the theory. For example, the well-known theorem of Jordan (a plane simple closed curve divides a plane into two connected components and is their common boundary) is obvious, but has a rigorous proof, which is important for the natural development of topology [19].

The existence theorem somewhat changes the approach to design in the sense of its abstract representation. It becomes advisable to introduce the concept of «design space». It is an ideal space in which any known and unknown to us, however, given this idealization, products not withdrawn from the design space are located, the existence of which is assumed in the named space. Owing to such step, the traditional concept of construction in this case can be replaced by the abstraction «withdrawal of technical objects from the design space», which is convenient for formalizing the presentation. So, it is not about the reliability of the existence of designs, since this fact is proved by the existence theorem with respect to real designs, but about what specific design needs to be «removed» from the design space in order to achieve the given real parameters and by what method it is done. In the design space, only real designs are envisaged, that is, those whose parameters do not contradict physical laws both separately and in certain combinations.

To derive the existence theorem for design, let's apply the following axioms:

A1. Any design is completely determined by its elements and its structure.

A2. All designs are additive compositions. Formalized entry:

$$\forall K(K_m = \langle K_1 + K_2 + \dots + K_n \rangle),$$

where K – some design; when adding an index – a specific design; K_{im} – design that is the i -th element of K_m design.

A3. In any design, the order relation is:

$$\forall K(\langle K_1 + K_2 + \dots + K_n \rangle = K_m \neq K_1 + K_2 + \dots + K_n + K_{n-1}).$$

Let's distinguish between the concepts of strict and non-strict order in the sense adopted in mathematics.

A4. Any design is a consequence of another design (has a predecessor, has an analog):

$$\forall K(K_a \Rightarrow (K_b \Rightarrow K_a)),$$

where K – the total number of designs; K_a, K_b – any concrete designs. These notations are saved for writing the following axioms.

A5. The transitivity relation takes place in designs:

$$(K_a \Rightarrow (K_b \Rightarrow K_c)) \Rightarrow ((K_a \Rightarrow K_b) \Rightarrow (K_a \Rightarrow K_c)),$$

where K_c – is any particular design. The remaining notations are given in axiom A4. The quantifier of universality in the record of this axiom is not used.

The statement about the existence of various relations in the designs is adopted taking into account that specific parameters are indicated for their comparison. Parameters, applied to designs, are defined characteristics of the product that define the functions that it performs. In the apparatus of mathematical logic, applied in this case, this period is used for the name of variables that are freely used in the formulas.

A6. The truth of the implication of designs contributes to their entry into one class according to the parameters of truth:

$$K_a \Rightarrow (K_b \Rightarrow (K_a \wedge K_b)).$$

A7. Correspondence of designs provides for the use of any of them according to the parameters of compliance:

$$((K_a \wedge K_b) \Rightarrow K_a) \vee ((K_a \wedge K_b) \Rightarrow K_b).$$

A8. Any design can be connected with another design:

$$(K_a \Rightarrow (K_a \vee K_b)) \wedge (K_b \Rightarrow (K_a \vee K_b)).$$

In axiom A8, it is taken into account that the conditions for design can always be constructively ensured.

A9. If any design follows from other designs and with each one separately, then it will also follow from the logical sum:

$$(K_a \Rightarrow K_c) \Rightarrow ((K_b \Rightarrow K_c) \Rightarrow ((K_a \vee K_b) \Rightarrow K_c)).$$

A10. If the design is excluded for inconsistencies with any parameter, then this is the reason to exclude, for the same reason, the design from which it was derived:

$$(K_a \Rightarrow K_b) \Rightarrow ((K_a \Rightarrow \neg K_b) \Rightarrow \neg K_a).$$

A11. Any design can be replaced:

$$K_a \Rightarrow (\neg K_a \Rightarrow K_b).$$

A12. An exception to the design exception is the introduction of this design:

$$\neg \neg K_a \Rightarrow K_a.$$

The rules of inclusion are taken from the calculation of predicates of the first order, using predominantly the substitution rule and the modus ponens (inclusion scheme) [18]. Putting the design semantics into the modus ponens (MP), MP can be described as follows: from the well-known accepted design K_a and the truth of the rule (or algorithm)

for obtaining new designs $K_a \Rightarrow K_b$, a new acceptable construction K_b follows.

In the form of a formal entry:

$$MP = \frac{K_a(K_a \Rightarrow K_b)}{K_b}. \quad (1)$$

To prove the existence theorem for design, the following lemma is proved: all classes of designs are infinite «in breadth» and «in depth».

The term «infinity in breadth» defines an infinite number of designs of any class. The term «infinity in depth» defines series (including infinite in length and quantity) that can be formed with the beginning and/or continuation between any fixed pair of adjacent designs. The construction of the series is shown below.

The method of induction is used for the proof. The determination of the proof by induction is described quite fully in the classical works on the basics of mathematics and the theory of proof [12, 13, 15]. It is revealed by the example of positive integers, namely: assuming the truth of a certain statement, for example, about the number 1, let's conclude that when it is true also for any number n , it will be true for the number $n+1$. So the conclusion: this statement is true for any number of the natural number. Proceeding from the reference about the infinity of the set of designs, it should be clarified that the proof will be carried out by transfinite induction [3]. In the sequel, in [3], the operation for generating numbers is the assignment of the number 1 to the previous number, and, given the concreteness of the construction method, can't in this case cause an objection during the derivation by induction.

The use of this method in designs makes it as simple as possible to simplify the procedure for generating a design by reducing it, to the extent possible, by adding simple elements. In addition, to strengthen the evidence by induction significantly increased the number of investigated objects and their varieties, causality and other factors were taken into account. The use of cause-effect relationships is illustrated by an example. There are 3 any designs with fixed identical properties. If one of them has discovered a new property, it is possible to consider with great probability that this property is in others. The higher the probability, the more properties are considered. It is clear that this should be essential properties.

Let's consider any class of designs. Based on [3], a class of design will be called any of their varieties that has a common feature (attributes) that does not intersect in pairs with designs in which the given feature is absent. Designs are assigned to the same class, in general, have differences between themselves, but the equivalence by attributes is divided into classes.

To concretize the proof, let's use a class of real designs, for example, rotary-type switches with elastic fixation, used in measuring instruments. Let's consider the designs that are inventions. Let's arrange them in a row by the dates of registration of applications for inventions (author's certificates) or by publication dates (other sources). Let's denote the design [23] – K_1 , the design [24] – K_n , the design [25] – K_{n+1} .

The first part of the proof. Design K_1 is the oldest in this class and can be started with it. An essential pro-

perty that is taken into account at the beginning is the reliability of the fixator. The validity of the statement about fixators is that if the lock contains a leaf spring that is connected to the handle of the switch handle, the fixation elements in it and the recesses for these elements in the body of the device, then the lock will provide an appropriate level of reliability. The level of reliability is determined by the maximum number of shifts that the fixator can guarantee. It is clear that in the comparison, the same conditions must be met: dimensional and other dimensions, material properties, test modes, etc. In this case, it is impossible to consider in detail the structural elements in the transition from one design to another, however, when formalizing designs, this issue is given attention. Fixators of the considered class, developed after K_1 , have the same level of reliability, but differ in structural elements, taking into account the different versions of their use in products. The high reliability requirements have necessitated the creation of a fixator [24], designated n_n , in which, in order to avoid cases of spring skewing and loss of fixation elements, the spring holes under the fixing elements are located on the axis of symmetry perpendicular to the wide sides of the flat rod of the switch handle. The appearance of the K_{n+1} design is associated with the need to further improve the reliability of the fixators by preventing damage to the protective coating of the metal rod of the handle during the clamping of a flat spring on it.

In the process of mastering the production of the design it turned out that in order to increase labor productivity in assembly operations it is advisable to make significant changes in the design of the fixator. The new design of K_{n+2} is also recognized by the invention [26]. In the future, the question of use the robots in the assembling changes the design K_{n+2} in accordance with new performance requirements, as a result of which a new fixer K_{n+3} appears (Fig. 1).

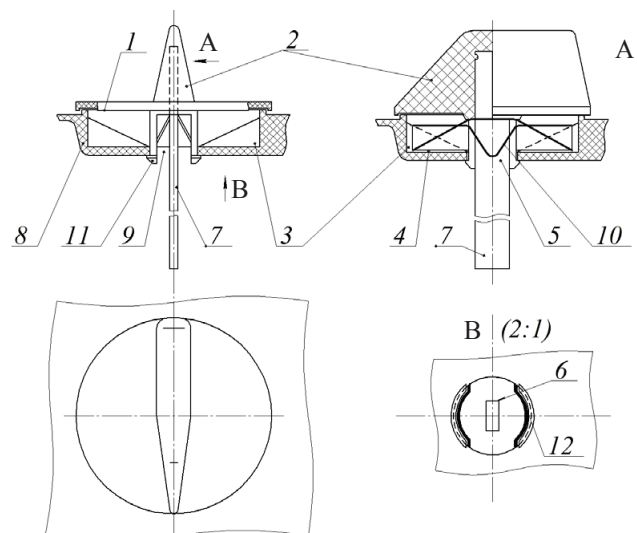

Fig. 1. Fixator K_{n+3}

Let's consider briefly the design K_{n+3} . The fixator has: a body 1 with an opening for the rotary handle 2 and with a recess 3 for the fixing elements 4, a leaf spring 5 with fixing elements 4 and a hole 6 for the flat rod 7

of the rotary handle 2. The handle 2 has, except rod 7, trunnion 8. In the trunnion 8 there is a groove 9 parallel to the wide sides of the rod 7. The groove 9 is arranged in such way that its longitudinal plane of symmetry is combined with the longitudinal plane of symmetry of the rod 7, with the plane of the rod 7 parallel to its wide sides. From the same plane of symmetry of the rod 7, the longitudinal plane of symmetry of the spring 5 coincides with the longitudinal plane of symmetry of the spring 5. The fixing elements 4 of the spring 5 have the shape of consoles, they are in the recesses 3, thereby fixing the handle 2 relative to the body 1. The flat rod 7 of the handle 2 is intended to be connected to one or several switches. Accordingly, the fixation of the handle 2 corresponds to the set position of the switches. The elements of the interaction of the spring 5 with the handle 2 are located in the groove 9. These elements include an opening 6 and lateral curly symmetric elastic protrusions 10 of the spring 5. At the end of the trunnion 8 is located a conical rim 11 with a taper toward the free end of the rod 7. To improve the elasticity of the halves trunnions 8 formed by the groove 9, longitudinal grooves 12 are made therein. The length of the spring 5 is smaller than the handle diameter 2.

Features of the fixator K_{n+3} :

- first, the spring 5 is put onto the rod 7 through the openings 6 until it is positioned in the groove 9. Moreover, the protrusions 10 abut against the side walls of the groove 9, trying to move them apart, and, locking up, prevent the spring 5 from withdrawing the groove 9;
- hereinafter, the handle 2 with the spring 5, as a single unit, is inserted into the body 1 from the side of the recesses 3 and, thanks to the conical rim 11, is fastened to the body 1,
- at setting, both parts of the trunnion 8 are bent, then, as a result of the action of the elastic forces, they occupy the initial position;
- in addition, the protrusions 10 extend the halves of the trunnion 8, ensuring a secure grip of the handle 2 in the body.

The fixator K_{n+3} works as follows: switching is carried out by turning the handle 2, on the rod 7 of which the rotors of the switches are located. After the handle 2 has been rotated to the predetermined position, the elements 4, under the action of the elastic forces of the spring 5, enter the corresponding recess 3 of the body 1, fixing the handle 2 and the rotor of the switches in the required switching position. The body 1 can be separate or combined with the body of the device.

Thus, as new requirements arise, new designs are created (or pulled out of the design space), according to new requirements. Such process is endless, especially considering that all nodes, parts and their elements can undergo significant changes at any coordinate, in any combination. This statement completes the proof of the infinity of designs «in breadth», since it is possible to construct a similar series from any other designs.

The second part of the proof. After the release of devices with K_n fixator for several years, new requirements led to the appearance of the K_{n+1} design, which continues a series of fixators. However, there was a need to improve the processability and durability of the assembly into which the fixator enters. These requirements

relate to the front panel of the device. On it there are a handle, a spring and other elements of the fixator. Since the handle with the flat rod, the leaf spring and the fixation elements were taken unchanged with K_n , the design should follow K_n . However, after K_n , K_{n+1} is already in the series. Thus, the new design must leave the gap between K_n and K_{n+1} , adding a new dimension to the series, supposedly «deepening» it. Let's denote this design by $K_{n(n+1)}$. It is described in [27]. Then new designs can be created between the constructions K_n , $K_{n(n+1)}$ and K_{n+1} in accordance with $K_{n(n(n+1))}$ and $K_{n(n(n+1)),(n+1)}$, etc.

Let's consider the designs are significantly different from the previous ones, for example, machines for cleaning grain [28, 29]. Let's denote by [28] – M_1 , [29] – M_2 . At this stage, the proofs will be limited to a brief fragment of the series, considering that the conclusions, due to repeated situations, extend to the entire series. The machine is characterized in that, in order to better clean the holes of the drum, it has an additional rotor from several disks, which are fastened by vertical struts, mounted concentrically mainly to the rotor, and cylindrical cleaners are fixed to the posts of the additional rotor. In the machine M_2 , in order to further increase the cleaning degree of the sieve drum, the cleaners have disc bristles and bristles installed diametrically opposite to the sieve drum. In addition, to move the grain layer from top to bottom, the grating drum performs, together with the rotational motion, an axial oscillatory motion. The disadvantage of the machine M_1 , and more of the M_2 machine, is the increased wear of the cleaners and grilles due to the fact that the cleaners, having friction clutches with the grill drum, do not oscillate along the rotation axis with the drum. This is the cause of intense destructive friction between the cleaners and the drum, the negative results of which increase the natural presence of a large number of holes in the lattices. To eliminate this drawback, a new design is proposed. Let's designate it as $M_{1;2}$. Although the creation of $M_{1;2}$ has a goal different from that of M_1 and M_2 , its main constructive elements are taken from both M_1 and M_2 , therefore it is impossible to continue the series, it must leave M_1 and M_2 , giving rise to a new series.

Such steps are possible for any pair of designs that are adjacent in a row. This process is infinite, both in terms of designs in the series, and in the number of rows. Further consideration of the designs of other classes will be superfluous. The lemma is proved.

The formalized notation of the lemma is:

$$\forall K(\langle K_1, \dots, K_n \rangle \Rightarrow \langle K_1, \dots, K_n, K_{n+1}, K_{n+2}, \dots, K_\infty \rangle) \\ \dots \leftarrow K_{n(n(n+1))} \leftarrow \downarrow K_{n(n+1)} \rightarrow K_{(n(n+1)),(n+1)} \dots \rightarrow. \quad (2)$$

Designations of designs are provided in the proof. It should be added that the letter K without the index is the general designation of design of an arbitrary class. When it joint to the universal quantifier, it is possible to read: «For all designs». K_∞ means any design with an infinite extension of the series.

Consequent 1. All classes of designs are countless sets.

Let's take any series of designs, for example, the already mentioned instrumental fixators, and put them into a one-to-one correspondence to the positive integers, numbering each design in a sequence of positive integers. However,

as indicated in the derivation of the lemma, a new design can always be obtained between any two designs. Accordingly, set of designs are countless according to [3].

Consequent 2. Designs form a set of cardinality of the continuum.

In this case, the method given in the completion of Consequent 1 is used. By obtaining new designs and putting them in correspondence with rational and irrational numbers, let's pass to the designation of designs by real numbers. It is known that real numbers are continuous in their plural and the power of their set is equal to the power of the continuum. Accordingly, the designs form a set of power of the continuum.

Let's note that the concept of «power» in the set-theoretic sense is analogous to the concept of «quantity» when applied to infinite sets.

6. Research results

Consequences 1 and 2 do not exhaust the list of consequences of the existence theorem, which have an applied meaning [30]. They can be supplemented with results on optimizing the shape of parts and others. In addition, there are consequences that are of theoretical interest. For example, the consequence is that any set of designs has a counted subset, that the set of constructions is open, the ratio of cardinalities of sets and subsets of constructions, etc. However, a large number of consequences should not overshadow an important question: is the existence theorem for designs significant?

It is known that the formula is significant if it is identically true. Each general-meaningful formula expresses a certain law [14]. In order to clarify the general significance of the existence theorem for designs, including by analogy, let's dwell on some well-known scientific fact that are revealed the law. Let's consider, for example, Newton's first law (the law of inertia), according to which, in the absence of external forces, or in their mutual equilibrium, the material body maintains a state of rest or moves uniformly relative to the inertial frame of reference. The formal record of this law can be as follows:

$$\forall T(J \Rightarrow (\nu \vee \bar{\nu})), \quad (3)$$

where T – any material body, which is regarded as a material point; J – inertia; ν – velocity of the body T , which, due to the inertia of the adopted reference frame, can either be equal to zero, or have a rectilinear direction and a constant value. The equality of velocity to zero is indicated in the formula by one of the symbols of negation – the line above the letter.

In formula (3), the disjunction has a separative meaning, that is, only one of the two determinations is claimed. So, the formula will be fulfilled if the body is either at rest, or moves uniformly and rectilinearly. Consequently, it is semantically true in the indicated real cases of the manifestation of the property under consideration in the established volume of the formula. In other words, if the interpretation is fixed and the formula is always fulfilled in the specified interpretation, then the formula is meaningfully true. In addition, formula (3) is identically true syntactically, in its formally logical construction. So, proceeding from the general significance of the considered formula and its semantic truth, there is reason to assert that it expresses the law.

If pass the same approach from the above-mentioned law to the existence theorem for designs, let's trace the analogy. For the existence theorem and for consequences 1 and 2, their formal notation is identically true formulas. In the future, the formulas of the existence theorem and its consequences are semantically fulfilled in all real cases. For greater plausibility, let's give the formula for the existence theorem to the following form:

$$\begin{aligned} \exists K_x((K_1 \vee K_2 \vee \dots \vee K_n) \Rightarrow \\ \Rightarrow (p_1 \vee p_2 \vee \dots \vee p_n \vee \bar{p}_1 \vee \bar{p}_2 \vee \dots \vee \bar{p}_n)). \end{aligned} \quad (4)$$

In this formula, its identity with truth is syntactically clearer.

Retaining the previous notation, the formula (4) can be read as follows: there are designs that satisfy any physical parameters. Such theory inevitably encounters the mathematical idealization. Returning to the abstraction of the design space, it is logical to rely on the effectiveness of the actual situation, according to which new requirements only arise, and the constructions that correspond to them already exist in the design space. Such approach formally reduces design to the methods of removing the outlines of the necessary nodes and details from the design space of the outlines of the design is any of its reflections that allows to pass to a materialized product, in other words, a descriptive or physical model. A descriptive model is, in particular, a graphic display (drawings) and mathematical modeling.

7. SWOT analysis of research results

Strengths. Among the strengths of this research, it should be note the proofs of the existence theorem for designs. The obtained results on the development of the theory of recording designs and the implementation of formalized operations for their creation improve the intellectual design process and contribute to the expansion of the use of CAD. In particular, the simplification of logical-mathematical design records is an important component of their optimization. The result of the proposed optimization is an increase in the productivity of engineering and design work, a reduction in their prime cost. Drawing up the designed structures by classes and series makes it possible to simplify the process of scientific and technical selection of designs that better meet the requirements for them. The system of excluding a whole number of designs according to a certain common feature does not satisfy the search conditions, increases the productivity of the process of creating new designs many times and is well suited to the automation process.

Weaknesses. The weaknesses of the research are related to the rather high influence of the heuristic component on the process of scientific and engineering search. Full formalization of this process can lead to a halt in the development of scientific and technical thought. There is a risk of reducing the process of construction to the reproduction of an infinite number of similar designs that differ in certain characteristics, but lie within the same constructive series.

To prevent the negative impact of the proposed theory on the rate of technological progress, it is necessary to strictly limit the field of its use. This theory is appropriate

to use to optimize the design of entire products or their individual components, automate the process of searching for a better prototype for improvement in a combination of features.

Opportunities. On the other hand, the continuous development of technologies allows creating fundamentally new designs with a certain set of characteristics. Thus, even the concept of a new product can lay the beginning of a series or even a class of designs, the development of which can be systematized according to the presented theory. Because it is at the time of the emergence of the idea of a fundamentally new design that an unlimited number of designs arise, which originate from it.

Prospects for further research in this case should be focused on the process of automating the creation of a constructive series based on an innovative conceptual design. In addition, it is important to study the algorithmization process of establishing the criteria of materiality and coding changes in the product. This will create an electronic database of non-existent physical structures, even before the design phase can be analyzed for compliance with the tasks assigned or narrow down the range of search in the design, cutting off the undesirable series.

The potential profitability of introducing such technology is illustrated by the time spent on designing. The design of medium complexity, which has a prototype, is designed for 1–2 months. The design that there are no prototypes, is being prepared for implementation from 6 months and more. The introduction of the proposed theory into reality can shorten the design time in many cases, which will reduce the cost of design work by an average of 20–30 % minimum.

Threats. The main «threat» for the research results is the difficulty in introducing research results into a specific product. In addition to the extraordinary science intensity and high intellectual costs of a whole group of specialists from different fields of knowledge, appropriate capital investments are needed. The lack of guaranteed quick and high results is a deterrent for potential investors.

Another risk is the wide and rapidly growing market of computer-aided design systems from the world's software leaders. And although analogues of a potential software product created on the basis of research results do not exist in the public domain, it is not a fact that such algorithms are not available at the development and research stage, especially in the field of artificial intelligence.

8. Conclusions

1. The existence theorem for designs is proved, for which it is established that the set of designs is infinite. Thus, in some abstract space, all designs originating from a particular class or series of details already exist. Thus, the design process is reduced to isolating from an infinite set of exactly those designs that satisfy the requirements of engineering search and compare them according to certain criteria, for example, cost or material intensity.

The high general significance of the existence theorem for designs allows to consider it as a law. Moreover, the resulting formula for the existence of designs and a formalized notation for the lemma are valid for any set of designs

2. A technique is proposed for obtaining an infinite set of designs by adding separate constructive elements or

features that correspond to certain properties. It is shown that there are designs that satisfy any physically real parameters and requirements, their real combinations, while the design is the primary component. Such statements have the force and significance of laws, even if some of them seem obvious, allow to obtain a well-thought-out correct design theory of machines and devices as a meaningful interpretation, a model of logical computations.

3. Regularities in the classes and series of the set of designs that determine their properties are revealed. The ways of optimization and increasing the productivity of the design process are proposed by establishing the connection between the features of the designs and their coding according to the chain of successive transformations. Design coding in place in the chain of transformations opens up wide prospects for automation of the design process.

4. It is established that the obtained results on the development of the theory of design recording and the performance of formalized operations for their creation improve the intellectual design process and contribute to the expansion of the use of CAD. In particular, the simplification of the logical-mathematical recording of designs is a component of their optimization, due to which the time and cost of designing new structures are reduced by 20–30 %.

References

1. DSTU ISO 9001-95. Systemy yakosti. Model zabezpechennia yakosti v protsesi proektuvannia, rozroblennia, montazhu ta obsluhovuvannia [Text]. – Introduced from July 01, 1996. – Kyiv: Derzhspozhyvstandart Ukrainy, 1996. – 30 p.
2. DSTU 3974-2000. Systemy rozroblennia ta postavlennia produkt-sii na vyrobnytstvo. Pravyla vykonannia doslidno-konstruktor-skykh robot [Text]. – Introduced from November 27, 2000. – Kyiv: Derzhspozhyvstandart Ukrainy, 2000. – 38 p.
3. Aleksandrov, P. S. Vvedenie v teoriiu mnozhestvy i obshchuiu topologiiu [Text] / P. S. Aleksandrov. – Moscow: Nauka, 1977. – 368 p.
4. Kolmogorov, A. N. Elementy teorii funktsii i funktsional'nogo analiza [Text] / A. N. Kolmogorov, S. V. Fomin. – Moscow: Nauka, 1976. – 544 p.
5. Lavrov, I. Problems in Set Theory, Mathematical Logic and the Theory of Algorithms [Text] / I. Lavrov, L. Maksimova; ed. by G. Corsi. – Springer US, 2003. – 282 p. doi:10.1007/978-1-4615-0185-5
6. Sigorskii, V. P. Matematicheskii apparat inzhenera [Text] / V. P. Sigorskii. – Kyiv: Tehnika, 1975. – 768 p.
7. Andreev, I. D. Teoriia kak forma organizatsii nauchnogo znaniia [Text] / P. S. Aleksandrov. – Moscow: Nauka, 1979. – 303 p.
8. Cattaneo, M. E. G. V. The likelihood interpretation as the foundation of fuzzy set theory [Text] / M. E. G. V. Cattaneo // International Journal of Approximate Reasoning. – 2017. – Vol. 90. – P. 333–340. doi:10.1016/j.ijar.2017.08.006
9. Leigh, J. R. Neural networks, fuzzy logic, genetic algorithms, learning systems intelligent systems [Text] / J. R. Leigh // Control Theory. – IET, 2004. – P. 225–248. doi:10.1049/pbce064e_ch17
10. Maciejewski, A. J. On algebraic construction of certain integrable and super-integrable systems [Text] / A. J. Maciejewski, M. Przybylska, A. V. Tsiganov // Physica D: Nonlinear Phenomena. – 2011. – Vol. 240, No. 18. – P. 1426–1448. doi:10.1016/j.physd.2011.05.020
11. Kuru, S. The Perlick system type I: From the algebra of symmetries to the geometry of the trajectories [Text] / S. Kuru, J. Negro, O. Ragnisco // Physics Letters A. – 2017. – Vol. 381, No. 39. – P. 3355–3363. doi:10.1016/j.physleta.2017.08.042
12. Stratulat S. Mechanically certifying formula-based Noetherian induction reasoning [Text] / S. Stratulat // Journal of Symbolic Computation. – 2017. – Vol. 80. – P. 209–249. doi:10.1016/j.jsc.2016.07.014

13. Kaufman, A. Geometrical Factor Theory of Induction Logging [Text] / A. Kaufman, G. Itskovich // Basic Principles of Induction Logging. – Elsevier, 2017. – P. 173–226. doi:10.1016/b978-0-12-802583-3.00006-x
14. Silver, J. H. Some applications of model theory in set theory [Text] / J. H. Silver // Annals of Mathematical Logic. – 1971. – Vol. 3, No. 1. – P. 45–110. doi:10.1016/0003-4843(71)90010-6
15. Hilbert, D. Grundlagen der Mathematik I (Grundlehren der mathematischen Wissenschaften) (German Edition) [Text] / D. Hilbert, P. Bernays. – Ed. 2. – Springer, 1968. – 480 p.
16. Engstrom, F. Dependence Logic with Generalized Quantifiers: Axiomatizations [Text] / F. Engstrom, J. Kontinen, J. Vaananen // Lecture Notes in Computer Science. – 2013. – P. 138–152. doi:10.1007/978-3-642-39992-3_14
17. Perez-Gellego, P. Using ensembles for problems with characterizable changes in data distribution: A case study on quantification [Text] / P. Perez-Gellego, J. R. Quevedo, J. J. del Coz // Information Fusion. – 2017. – Vol. 34. – P. 87–100. doi:10.1016/j.inffus.2016.07.001
18. Kuznetsov, O. P. Diskretnaia matematika dlia inzhenera [Text] / O. P. Kuznetsov, G. M. Adelson-Velskii. – Moscow: Energiia, 1980. – 344 p.
19. Vinogradov, I. M. Matematicheskaia entsiklopediia [Text] / ed. by I. M. Vinogradov. – Moscow: Sovetskaia Entsiklopediia, 1979. – Vol. 2. – 1104 p.
20. Fichera, G. Existence Theorems in Elasticity [Text] / G. Fichera // Linear Theories of Elasticity and Thermoelasticity. – Berlin, Heidelberg: Springer, 1973. – P. 347–389. doi:10.1007/978-3-662-39776-3_3
21. Freiman, L. S. Teoremy sushchestvovaniia [Text] / L. S. Freiman. – Moscow: Nauka, 1971. – 135 p.
22. Chapra, S. Numerical Methods for Engineers [Text] / S. Chapra, R. Canale. – Ed. 7. – New York: McGraw-Hill Education, 2014. – 992 p.
23. Elektricheskii mnogopridel'nyi pribor [Text]: Patent of Austria 212427. – 1960.
24. Fiksator perekliuchatelia mnogopredel'nogo elektroizmeritel'nogo pribora [Text]: A. s. 646259 (USSR) / Grinberg I. P., Los L. V. – 1979. – Bull. No. 5.
25. Fiksator perekliuchatelia [Text]: A. s. 879578 (USSR) / Demchenko A. M., Grinberg I. P., Los L. V. – 1981. – Bull. No. 41.
26. Fiksator perekliuchatelia [Text]: A. s. 1126941 (USSR) / Demchenko A. M., Grinberg I. P., Los L. V. – 1984. – Bull. No. 44.
27. Kommutatsionnoe ustroistvo mnogopredel'nogo elektroizmeritel'nogo pribora [Text]: A. s. 987533 (USSR) / Grinberg I. P., Los L. V., Galitskii R. M., Bezusyi M. I. – 1983. – Bull. No. 1.
28. Vibrotsentrobezhnaia zernoochistitel'naia mashina [Text]: A. s. 485784 (USSR) / Goncharov E. S., Prilutskii A. N., Voloshin N. I. – 1975. – Bull. No. 36.
29. Zernoochistitel'naia mashina [Text]: A. s. 976539 (USSR) / Goncharov E. S. – 1978.
30. Liu, Y. Materials discovery and design using machine learning [Text] / Y. Liu, T. Zhao, W. Ju, S. Shi // Journal of Materials. – 2017. – Vol. 3, No. 3. – P. 159–177. doi:10.1016/j.jmat.2017.08.002

ОБОСНОВАНИЕ ТЕОРИИ СТРУКТУРЫ КОНСТРУКЦИЙ ТЕХНОЛОГИЧЕСКИХ МАШИН И ПРИБОРОВ

Рассматривается теория структуры конструкций технологических машин и приборов с получением на ее основе количественных критериев и примерами использования представленной теории. Обосновываются критерии собираемости, ремонтпригодности, унификации и функциональной насыщенности, позволяющие давать количественную оценку конструкциям на стадии их разработки. Доказано, что они объективно отражают техническое совершенство конструкций, поскольку не зависят от изменяющихся во времени факторов, таких как себестоимость.

Ключевые слова: теория структуры конструкций, критерии собираемости и ремонтпригодности, теорема существования конструкций.

Los Leonid, Doctor of Technical Sciences, Professor, Department of Mechanics and Agroecosystems Engineering, Zhytomyr National Agroecological University, Ukraine, ORCID: <http://orcid.org/0000-0003-4766-9812>

Kukharets Savelyi, Doctor of Technical Sciences, Associate Professor, Head of the Department of Mechanics and Agroecosystems Engineering, Zhytomyr National Agroecological University, Ukraine, e-mail: natallyatsyvenkova@gmail.com, ORCID: <http://orcid.org/0000-0002-5129-8746>

Tsyvenkova Nataliya, PhD, Associate Professor, Department of Mechanics and Agroecosystems Engineering, Zhytomyr National Agroecological University, Ukraine, e-mail: natallyatsyvenkova@gmail.com, ORCID: <http://orcid.org/0000-0003-1703-4306>

Holubenko Anna, Assistant, Department of Electrification, Automation of Production and Engineering Ecology, Zhytomyr National Agroecological University, Ukraine, e-mail: natallyatsyvenkova@gmail.com, ORCID: <http://orcid.org/0000-0001-5018-5312>

Tereshchuk Marina, Postgraduate Student, Department of Mechanics and Agroecosystems Engineering, Zhytomyr National Agroecological University, Ukraine, e-mail: marfa3127@yandex.ua, ORCID: <http://orcid.org/0000-0002-3020-4528>